

Kidde ECS™ Advanced Delivery Fire Suppression System Component Description



Effective: June 2014

K-90-114

Grooved Nut Discharge Head and Plain Nut Discharge Head P/Ns: 81-872442-000 and WK-872450-000

FEATURES

- Grooved Nut Discharge Head Can Only be Actuated with a Control Head
- Grooved Nut Discharge Head is for Use with Single Nitrogen Driver Systems Only (225 lb. and 395 lb. Systems)
- Plain Nut Discharge Head Can be Actuated by Control Head or Back Pressure from Manifold
- Plain Nut Discharge Head is Used with Multiple Nitrogen Driver Systems (i.e., 675 lb. and 1010 lb. Systems)
- UL Listed
- FM Approved
- RoHS Compliant

DESCRIPTION

At installation, each Kidde ECS ADS Fire Suppression System with FM-200® Agent nitrogen driver cylinder and valve assembly must be equipped with a discharge head to actuate the cylinder valve. The discharge head is assembled to the top of the nitrogen driver cylinder valve and contains a spring-loaded piston which, when actuated by nitrogen pressure, is designed to depress the main check in the valve and transfer the contents of the nitrogen tank into the agent cylinder. The transfer outlet is designed to mate with the swivel adapter on the 1-in. flexible transfer hose (P/N 06-118207-00X). The discharge head also contains an integral stop check which, in the event that a cylinder is removed from the Kidde ECS™ ADS System assembly, automatically prevents the loss of nitrogen during the system transfer. The grooved-nut discharge head only allows the cylinder to be actuated when a control head releases pilot pressure. Pressure entering the outlet from the manifold will not actuate the cylinder. The plain nut discharge head allows the nitrogen driver to be actuated by the control head (electric or pneumatic) or by back pressure discharge in the manifold. The plain nut discharge head is convenient for applications using multiple drivers for one agent cylinder.

Note: For additional detail regarding Kidde ECS™ ADS Systems and nitrogen manifolding, refer to the DIOM (P/N 06-236068-001).

INSTALLATION

1. Wipe off cylinder valve sealing surface.
2. Verify that the O-rings are installed in the mating surface grooves at the bottom of the swivel nut cavity. O-rings must be free of dirt or other contaminants. The O-rings have been lightly greased at the factory and should not require further greasing.
3. Make sure the pilot orifice located between the inner and outer O-ring is unobstructed.
4. Make sure the discharge port is clean and unobstructed.
5. Install the discharge head on the cylinder valve. Tighten securely.



The agent storage cylinder must be permanently connected to the system piping. Never attach the discharge head to the cylinder valves until the cylinders are secured in brackets or racking and the hose is attached to the agent cylinder. Under no circumstances should the discharge head remain attached to the cylinder valve after removal from service or during shipment, handling, storage or filling. In the event of inadvertent discharge, failure to follow these instructions could result in death, serious bodily injury and/or property damage.

MAINTENANCE

MONTHLY:

Inspect nitrogen driver discharge head for cracks, corrosion, grime, etc. Ensure that the discharge head is tightly secured to the nitrogen cylinder valve and connected to the agent cylinder with the 1-in. nitrogen transfer hose. If any defects are found during the monthly inspection, immediately contact a Kidde Distributor to service the systems.

SPECIFICATIONS

MATERIALS

- **Body:** Brass
- **O-rings:** Rubber
- **Spring:** Stainless Steel
- **Stop Check:** Brass
- **Weight:** 4.0 lb. (1.8 kg)

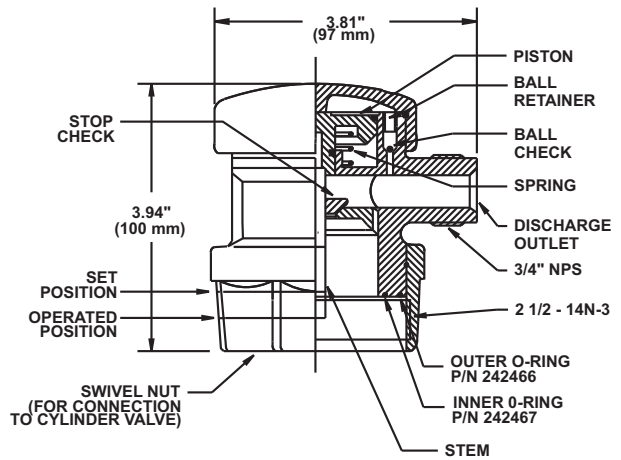

Figure 1. Discharge Head, Plain Nut:
For Use with Multiple Nitrogen Driver
675 lb. and 1010 lb. Systems

ORDERING INFORMATION

Part Number	Description
81-872442-000	Grooved Nut Discharge Head
WK-872450-000	Plain Nut Discharge Head

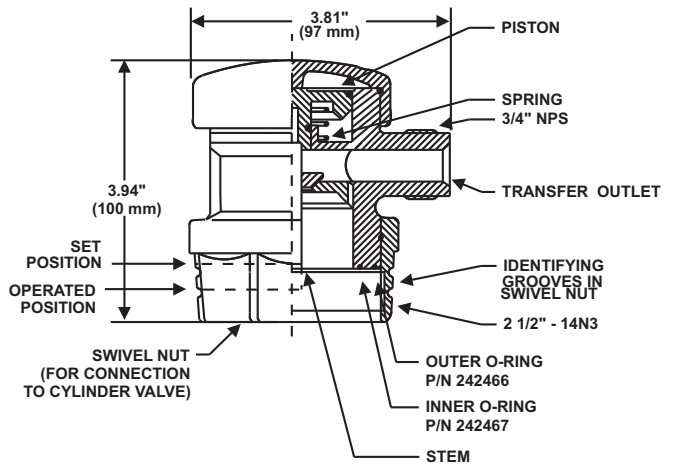

Figure 2. Discharge Head, Grooved Nut:
For Use with Single Nitrogen Driver
225 lb. ad 395 lb. Systems

FM-200 is a registered trademark of E.I. du Pont de Nemours and Company.
Kidde is a registered trademark of Kidde-Fenwal Inc. All other trademarks are the property of their respective owners.

This literature is provided for informational purposes only. Kidde-Fenwal, Inc. assumes no responsibility for the product's suitability for a particular application. The product must be properly applied to work correctly. If you need more information on this product, or if you have a particular problem or question, contact Kidde-Fenwal, Inc.

